

**THE  
GRAND ENCAMPMENT  
OF  
KNIGHTS TEMPLAR  
of the  
U.S.A.**

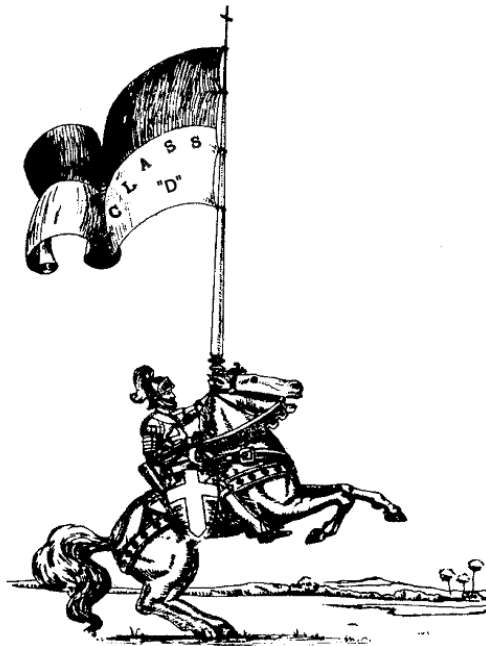

**COMPETITIVE DRILL MANUAL  
CLASS "D"  
ISSUED BY THE COMMITTEE ON DRILL REGULATIONS**

**DETAILED**

**INSTRUCTIONS**

**for**

**CLASS “D” TEAMS**

**in**

**TRIENNIAL COMPETITION**

**Issued by the Committee on Drill Regulations**

**January 2008**

**No changes for 2015 Drills**

**ALSO REFER TO**

**“DRILL REGULATIONS OF THE GRAND ENCAMPMENT OF KNIGHTS TEMPLAR OF THE USA”**

**SWORD MANUAL**

**THE SWORD MANUAL IS TO BE EXECUTED AT A CADENCE  
OF 90 PER MINUTE**

	Par.
Stand-at-ease .....	49
Attention.....	50*
Sir Knights Draw.....	85
Present.....	88
Carry .....	89
Salute.....	90
Order Swords .....	92
Support Swords .....	94
Swords Port.....	96
Arm Rest Swords .....	98
Shoulder Swords .....	100
Reverse Swords .....	102
Parade Rest.....	106
Attention.....	107*
Inspection Swords .....	108
Invert Swords .....	109
Guide Swords .....	111
Sir Knights Return.....	112
On Guard.....	119
Charge .....	128
Un-Cover.....	130
Re-Cover .....	131

**SWORD MANUAL**

The Captain will face the commandery while giving the necessary commands for the Sword Manual.

**ATTENTION (Par. 50 and 107)**

**Captain's Commands: 1. Commandery, 2. Attention.**

The command of execution for all movements while marching is given as either foot strikes the ground, except as otherwise prescribed; the movement commences when the FOLLOWING FOOT is planted.

Added March 2005

**FORWARD MARCH (Par. 59)**

Being at a halt.

**Captain's Commands:** 1. Forward, 2. March.

**Captain:** Commands: 1. *Forward.*

AT THE COMMAND FORWARD

Shift the weight of the body to the right leg, left knee straight.

**Captain:** Commands: 2. *March.*

AT THE COMMAND MARCH

Move the left foot smartly straight forward 30 inches, sole near the ground and plant it without shock (DO NOT ACCENT THE STEP); next in like manner advance and plant the right foot; continue the march. The arms swing naturally.

**MARK TIME (Par. 62)**

Being in March.

**Captain's Commands:** 1. Mark Time, 2. March.

AT THE COMMAND MARCH

At the command march, given as either foot strikes the ground; advance and plant the other foot; bring up the foot in the rear and continue the cadence by alternately raising each foot ABOUT TWO (2) INCHES and planting it LIGHTLY on a line with the other.

ALLOW THE MOVEMENT TO CONTINUE FOR AT LEAST EIGHT (8) COUNTS.

Being at a halt.

**Captain's Commands:** 1. Mark Time, 2. March.

AT THE COMMAND MARCH

Raise and plant the left foot and then the right, as described above. Do not accentuate the cadence by stomping.

ALLOW THE MOVEMENT TO CONTINUE FOR AT LEAST EIGHT (8) COUNTS.

NOTE: Any movement may be executed from Mark Time.

Revised March 2005

**HALF STEP (Par. 63)**

Being in March or at Mark Time.

**Captain's Commands:** 1. **Half Step**, 2. **March**.

**Captain:** Commands: 1. *Half Step*, 2. *March*.

AT THE COMMAND MARCH

At the command march, given as either foot strikes the ground, advance and take steps of 15 inches straight to the front.

**Captain:** Maintains his position three (3) paces in front of the center of the Commandery or beside the group of twos or threes, facing front.

ALLOW THE MOVEMENT TO CONTINUE FOR AT LEAST EIGHT (8) COUNTS.

Revised March 2005

**SIDE STEP (Par. 65)**

**Captain's Commands:** 1. **Right (Left) Step**, 2. **March**.

**Captain:** Facing team Commands: 1. *Right (Left) Step*.

**Captain:** Faces to the front and Commands: 2. *March*

AT THE COMMAND MARCH

**Each Guide and Knight:** Carry and plant the Right (Left) foot 10 inches to the right (left), bring the left (right) foot beside it and continue the movement in the cadence of quick time.

**Captain:** Executes Left (Right) Step with team by Carrying and planting the Left (Right) foot 10 inches to the left (right), bring the right (left) foot beside it and continue the movement in the cadence of quick time.

NOTE: All commands during the Side Step are given when the feet are together; take another step (Par 58), then execute.

Revised January 2008

**BACK STEP (Par. 66)**

Being at a halt or Mark Time.

**Captain's Commands:** 1. **Backward**, 2. **March**.

**Captain:** Commands: 1. *Backward* 2. *March*.

AT THE COMMAND MARCH

**Each Knight:** Take steps of 15 inches straight to the rear.

**Captain:** Maintains his position three (3) paces in front of and centered on the Commandery by moving forward at a half step.

NOTE: To arrest the march use Commandery Halt (Par. 67).

**TO HALT (Par. 67)**

Being in March.

**Captain's Commands:** 1. **Commandery**, 2. **Halt**.

**Captain:** Commands: 1. *Commandery*, 2. *Halt*.

AT THE COMMAND HALT

At the command halt, given as either foot strikes the ground; plant the other foot as in marching; raise and place the first foot by the side of the other. DO NOT ACCENT THE STEP.

**TO MARCH BY THE FLANK (Par. 68)**

Being in March.

**Captain's Commands:** 1. **By the Right (Left) Flank**, 2. **March**.

**Captain:** Commands: 1. *By the Right (Left) Flank*, 2. *March*. March is given as the right (left) foot strikes the ground.

AT THE COMMAND MARCH

**All Knights and Officers:** Advance and plant the left (right); then face to the right (left) in marching and step off in the new direction with the right (left) foot.

**TO MARCH TO THE REAR (Par. 69)**

Being in March.

**Captain's Commands:** 1. **To the Rear**, 2. **March**.

**Captain:** Commands: 1. *To the Rear*, 2. *March*. March is given as the right foot strikes the ground.

AT THE COMMAND MARCH

**All Knights and Officers:** Advance and plant the left foot; turn to the right about on the balls of both feet and immediately step off with the left foot.

**TO MARCH TO THE REAR (Par. 69)**

Being in column of threes, right in front

**Captain's Commands:** 1. **Ones to the Rear**, 2. **March**, 3. **Twos to the Rear**, 4. **March**, 5. **Threes to the Rear**, 6. **March**

**Captain:** Commands: 1. *Ones to the Rear*, 2. *March* (March being given on the Right Foot).

AT THE COMMAND MARCH

**No. 1 Knights of Each Three:** Execute To the Rear while maintaining cover and alignment.

**Captain:** Commands: 1. *Twos to the Rear*, 2. *March* (March being given on the Right Foot).

AT THE COMMAND MARCH

**No. 2 Knights of Each Three:** Execute To the Rear while maintaining cover and alignment.

**Captain:** Commands: 1. *Threes to the Rear*, 2. *March* (March being given on the Right Foot).

AT THE COMMAND MARCH

**Captain:** Execute To the Rear while maintaining cover and alignment.  
**No. 3 Knights of Each Three:**

To reassemble into a column of threes execute the above sequence a second time.

**ROUTE STEP (Par. 72)**

**Captain's Commands:** 1. **Route Step**, 2. **March**.

**Captain:** Commands: 1. *Route Step*, 2. *March*.

AT THE COMMAND MARCH

**All Knights and Officers:** The Knights lengthen or shorten the step at will, so that it will break the cadence, they are not required to preserve silence or keep step. Allow the movement to proceed long enough so that step and cadence are broken.

NOTE: It may be useful to assign some Knights to lengthen the step and some to shorten the step.

**TO RESUME THE CADENCE, STEP AND SILENCE**

**Captain's Commands:** 1. **Commandery**, 2. **Attention**.

**Captain:** Commands: 1. *Commandery*, 2. *Attention*.

AT THE COMMAND ATTENTION

**All Knights and Officers:** Bring the heels together and halt. DO NOT MARK TIME. Immediately step off on the left foot when the Captain starts the cadence count 1 etc. The Captain may count cadence 1-2-3-4 twice.

**ALIGNMENTS (Par. 74 & 75)**

NOTE: After aligning the team the Captain gives the command: *Front*, the movement is not complete until the knight giving the command faces front. The position for the knight to go to before facing front is determined by the position of the team. If the team is in a full commandery front go to the position three paces in front of and centered on the commandery and face front. If the team is less than a full commandery front go to the position three paces in front of the right file (if right dress) or the left file (if left dress) and face front. They may then move to a different position if necessary for the next command.



**ALIGNMENTS (Par. 74)**

(By File)

**Captain's Commands:** 1. **Right (Left)**, 2. **Dress**, 3. **Front**.

**Captain:** Commands: 1. *Right (Left)*, 2. *Dress*.

**AT THE COMMAND DRESS**

The base of the alignment having been established, each Knight moves up successively in quick time, shortening the last step, so as to be about six inches behind the alignment which should never be passed; each Knight then executes EYES RIGHT (LEFT), and moves on the line taking steps of two or three inches, places his Right (Left) arm against the arm of the Knight on his Right (Left), shoulders square to the front.

**Captain:** Verifies the alignment at the two pace interval from the Right (Left) Flank. He may order up or back such knights that may be in rear or advance of the line. When he is satisfied with the alignment Commands: 3. *Front*.

**AT THE COMMAND FRONT**

**Each Knight:** Turns his head and eyes smartly to the front.

**Captain:** Takes his position as described previously (Par. 74 & Par. 75) and faces front.

NOTE: If the captain deems it necessary to move a Knight or Knights up or back, only the Knight or Knights moved will be scored by their respective judges. The Captain will be scored only after the command front has been given.

**ALIGNMENTS (Par. 75)**

(From Column)

**Captain's Commands:** 1. **Right (Left)**, 2. **Dress**, 3. **Front**.

**Captain:** Commands: 1. *Right (Left)*, 2. *Dress*.

**AT THE COMMAND DRESS**

The base of the alignment having been established, the entire rank moves forward (by Threes or Section) and dresses up to the line as explained in Par. 74 above. Each Knight except the base file executes EYES RIGHT (LEFT).

**Captain:** Verifies the alignment at the two pace interval from the Right (Left) Flank. He may order up or back such knights that may be in rear or advance of the line. When he is satisfied with the alignment Commands: 3. *Front*.

**AT THE COMMAND FRONT**

**Each Knight:** Turns his head and eyes smartly to the front.

**Captain:** Takes his position as described previously (Par. 74 & Par. 75) and faces front.

NOTE: If the captain deems it necessary to move a Knight or Knights up or back, only the Knight or Knights moved will be scored by their respective judges. The Captain will be scored only after the command front has been given.

**WHEELING (Par. 80)**

Wheelings are of two kinds, on fixed or moving pivots. In all wheels, the guide on the marching flank keeps the pivot constantly in view (Paragraph 18); to this end, the Knight next to him keeps the line of his shoulders a little to the rear, but in the same direction.

**ADDENDUM (Par. 80)**

In the execution of all wheels, **whether on fixed pivots or moving pivots, head and eyes are turned simultaneously with the first step of the wheel. Head and eyes are turned back to the front simultaneously with the first step following the completion of the wheel. When the wheel terminates with a halt, head and eyes are turned simultaneously with the last movement of the halt; that is, as the feet are brought together** (Paragraph 67).

**Head Movements Following Successive Formulations into Line  
(Examples: Paragraphs 205, 207, 241, 303 and 304)**

In successive formations into line, **each element halts and dresses successively upon arriving in line. The Knights of each element complete the halt in unison with head and eyes straight to the front. On the first count after the halt is completed, head and eyes are turned in unison to dress.** A count is one-half of one second.

**WHEELINGS ON A FIXED PIVOT (Par. 81)**

**THE FIXED PIVOT IS USED IN WHEELING FROM LINE INTO COLUMN,  
OR FROM COLUMN INTO LINE.**

The pivot Knight marks time in place, turning to conform to the marching flank.

The Knight on the marching flank takes the full step and looks toward the pivot. All keep touch of elbows toward the pivot, head and eyes turned toward the marching flank, regulating the length of step accordingly.

Lengths Of Steps Are Approximate

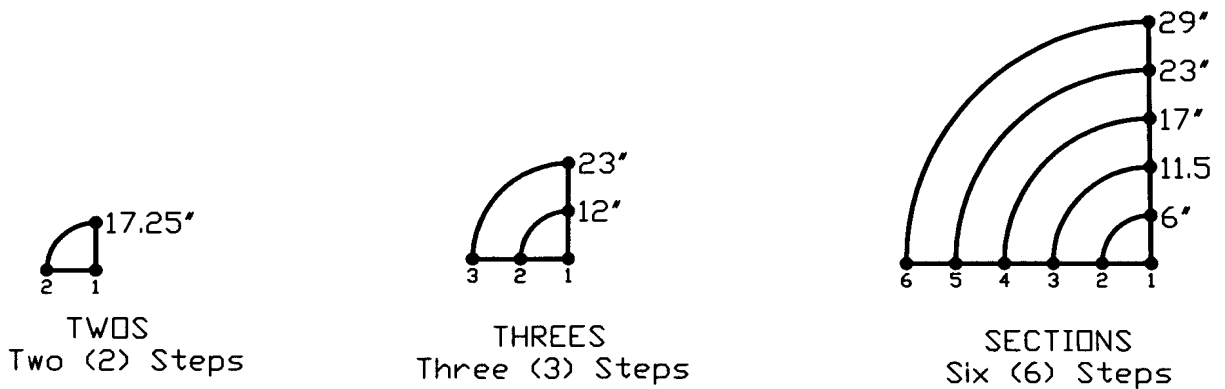

**WHEELING ON A MOVING PIVOT (Par. 82)**

**THE MOVING PIVOT IS USED IN CHANGING DIRECTION OF COLUMN IN MARCHING, AND IN SOME SUCCESSIVE FORMATIONS.**

The pivot Knight takes a short step, thus gaining ground forward, describing a circle the radius of which is always 30 inches, regulating the length of step to correspond to the marching flank. The Knight on the marching flank takes the full step (except when in a column of twos when the step shortens as shown below to just over 17 inches) and looks toward the pivot. All keep touch of elbows toward the pivot, head and eyes turned toward the marching flank, regulating the length of step accordingly.

Lengths Of Step Are Approximate

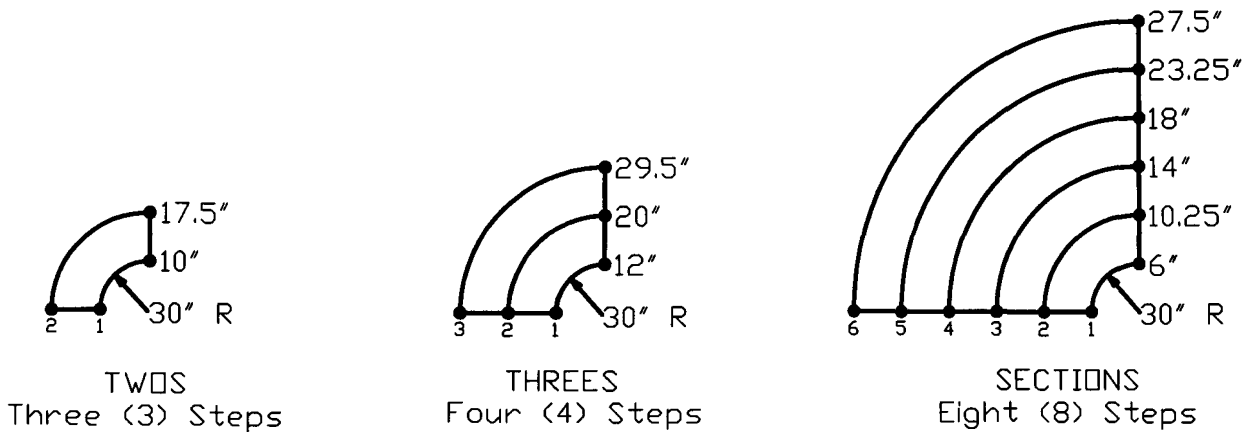

**OPEN RANKS (Par. 191)**

Being in Line, Halted.

**Captain's Commands:** 1. **Open Ranks**, 2. **March**, 3. **Front**.

**Captain:** Commands: 1. *Open Ranks*.

AT THE COMMAND OPEN RANKS

**No. 2 Knight:** Backstep six steps (Par. 66) to mark the new alignment of the rear rank.

**Captain:** Moves to the right flank two paces in prolongation of the alignment, facing the knight and sees that the No. 2 Knight is on a line parallel to and three paces behind the front rank, then places himself facing the left, three paces in front of the right file (No. 1 Knight) of the front rank, and commands: 2. *March*.

AT THE COMMAND MARCH

**Knights in Line:** The front rank, the odd numbered Knights, dress to the right without closing intervals; the even numbered Knights who constitute the rear rank, turn head and eyes to the right, backstep, halt a little in the rear of the alignment, and dress to the right without closing interval.

**Captain:** Faces left, moves to the right flank two paces in prolongation of the alignment, faces right superintends the alignment of the front rank, faces left, goes to the right of the rear rank (No. 2 Knights) verifies the alignment of the rear rank, faces right, then moves to a point three paces in front of the right file (No. 1 Knight) of the front rank, faces left and commands: 3. *Front*. Faces the front.

**CLOSE RANKS (Par. 192)**

**Captain's Commands:** 1. **Close Ranks**, 2. **March**.

**Captain:** Commands: 1. *Close Ranks*, 2. *March*.

AT THE COMMAND MARCH

**Knights in Rear Rank:** The rear rank closes in three steps, each Knight resuming his place in line.

**Captain:** Takes his position three paces in front of the center of the Commandery and faces the front.

**TO TURN ON A FIXED PIVOT AND HALT (Par. 195)**  
 Being in Line, Halted.

**Captain's Commands:** 1. **Commandery Right (Left)**, 2. **March**, 3. **Commandery**, 4. **Halt**.

**Captain:** Facing the Commandery commands: 1. *Commandery Right (Left)*, and faces the front and commands: 2. *March*.

AT THE COMMAND MARCH

**Captain:** Moves to the right (left) and marches to his position in the new alignment, three paces in front of the center of the Commandery, Halts, and faces about facing the Commandery, observing the completion of the movement and Commands: 3. *Commandery*, 4. *Halt* when the movement is half completed.

**No. 1 Knight:** Faces to the right (left) in marching without gaining ground in the new direction (Par. 52 Note last sentence).

**Knights in Line:** The Knights in line oblique to the right (left) and upon arriving at their place in line, place themselves abreast of the Knight on their right (left) and mark time, dressing to the right (left) until the command 4. *Halt* is given, then face front. Only those Knights who are in position halt; each of the others halts upon arriving in line, aligns himself to the right (left), and executes front without command.

**Captain:** When the No. 6 Knight takes his place in line, faces front.

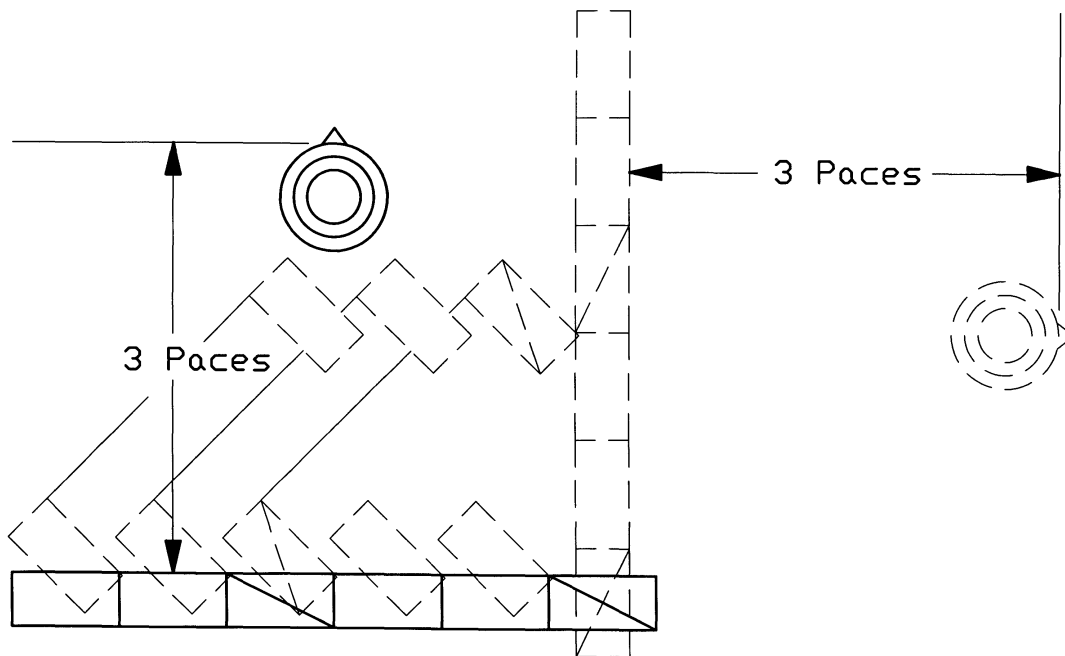

**TWOS RIGHT (LEFT) (Par. 197)**

Execution of this movement places the Commandery Right (Left) in Front.

Being in Line, Halted.

**Captain's Commands:** 1. **Twos Right (Left), 2. March.**

**Captain:** Commands: 1. *Twos Right (Left)*, moves to a point three paces in front of, and facing the No. 1 (No. 6) Knight and commands: 2. *March*.

AT THE COMMAND MARCH

**Knights in Line:** Each two wheels to the right (left) on fixed pivots (2 steps), taking the full step upon completion of the wheel, guiding to the Left (Right) (marching flank).

**Captain:** Places himself on the immediate left (right) of the No. 2 Knight (No. 5 Knight).

**TWOS RIGHT (LEFT) (Par. 197)**

Marching in Line in a Commandery Front.

**Captain's Commands:** 1. **Twos Right (Left), 2. March.**

**Captain:** Commands: 1. *Twos Right (Left)*, moves to a point three paces in front of the No. 1 (No. 6) Knight and commands: 2. *March*.

AT THE COMMAND MARCH

**Knights in Line:** Each two wheels to the right (left) on fixed pivots (2 steps), taking the full step upon completion of the wheel, guiding to the Left (Right) (marching flank).

**Captain:** Places himself on the immediate left (right) of the No. 2 Knight (No. 5 Knight).

**THREES RIGHT (LEFT) (Par. 197)**

Execution of this movement places the Commandery Right (Left) in Front.

Being in Line, Halted.

**Captain's Commands:**      **1. Threes Right (Left), 2. March.**

**Captain:**                      Commands: 1. *Threes Right (Left)*, moves to a point three paces in front of, and facing the No. 1 (No. 6) Knight and commands: 2. *March*.

AT THE COMMAND MARCH

**Knights in Line:**              Each three wheels to the right (left) on fixed pivots (3 steps), taking the full step upon completion of the wheel, guiding to the Left (Right) (marching flank).

**Captain:**                      Places himself on the immediate left (right) of the No. 3 Knight (No.4 Knight).

**THREES RIGHT (LEFT) (Par. 197)**

Marching in Line in a Commandery Front.

**Captain's Commands:**      **1. Threes Right (Left), 2. March.**

**Captain:**                      Commands: 1. *Threes Right (Left)*, moves to a point three paces in front of the No. 1 (6) Knight and commands: 2. *March*.

AT THE COMMAND MARCH

**Knights in Line:**              Each three wheels to the right (left) on fixed pivots (3 steps), taking the full step upon completion of the wheel, guiding to the Left (Right) (marching flank).

**Captain:**                      Places himself on the immediate left (right) of the No. 3 Knight (No.4 Knight).



**TO MARCH IN COLUMN OF TWOS TO THE FRONT (Par. 198)**

Being in Line, Halted.

**Captain's Commands:** 1. **Right (Left) by Twos, 2. March.**

**Captain:** Facing the Commandery, commands: 1. *Right (Left) by Twos, 2. March.*

AT THE COMMAND MARCH

**Right (Left) Two:** Moves straight to the front, shortening the first three or four steps.

**Captain:** Moves to the left (right) by the shortest route to his position on the immediate left (right) of the No. 2 Knight (No. 5 Knight).

**Second Two:** Wheel to the right (left) on fixed pivot, when its wheel is 1/2 completed, wheels to the left (right) 2/3 of a moving pivot and follows the right (left) two.

**Trailing Two:** Wheel to the right (left) on fixed pivots, move forward and wheel to the left (right) on moving pivots, on the same ground as the second two.

**TO MARCH IN COLUMN OF TWOS TO THE FRONT (Par. 198)**

Marching in Line.

**Captain's Commands:** 1. **Right (Left) by Twos, 2. March.**

**Captain:** Commands: 1. *Right (Left) by Twos, 2. March.* (On Right (Left) Foot).

AT THE COMMAND MARCH

**Right (Left) Two:** Takes one (1) step straight to the front, shortening the next three or four steps.

**Captain:** Moves to the right (left) by the shortest route to his position on the immediate left (right) of the No. 2 Knight (No. 5 Knight).

**Second Two:** Takes one (1) step straight to the front, wheel to the right (left) on fixed pivot, when its wheel is 1/2 completed, wheels to the left (right) 2/3 of a moving pivot and follows the right (left) two.

**Trailing Two:** Takes one (1) step straight to the front, wheel to the right (left) on fixed pivots, move forward and wheel to the left (right) on moving pivots, on the same ground as the second two.

**TO MARCH IN COLUMN OF THREES TO THE FRONT (Par. 198)**

Being in Line, Halted.

**Captain's Commands:** 1. **Right (Left) by Threes, 2. March.**

**Captain:** Facing the Commandery, commands: 1. *Right (Left) by Threes, 2. March.*

AT THE COMMAND MARCH

**Right (Left) Three:** Moves straight to the front one (1) full step, shortening the next four steps.

**Captain:** Moves to the right (left) by the shortest route to his position on the immediate left (right) of the No. 3 Knight (No. 4 Knight).

**Second (First) Three:** Wheel to the right (left) on fixed pivot, when its wheel is 2/3 completed, wheels to the left (right) 3/4 of a moving pivot and follows the right (left) three.

**TO MARCH IN COLUMN OF THREES TO THE FRONT (Par. 198)**

Marching in Line.

**Captain's Commands:** 1. **Right (Left) by Threes, 2. March.**

**Captain:** Commands: 1. *Right (Left) by Threes, 2. March.* (On Right (Left) Foot).

AT THE COMMAND MARCH

**Right (Left) Three:** Takes two (2) steps straight to the front, shortening the next four steps.

**Captain:** Moves to the right (left) by the shortest route to his position on the immediate left (right) of the No. 3 Knight (No. 4 Knight).

**Second (First) Three:** Takes one (1) step straight to the front, wheel to the right (left) on fixed pivot, when its wheel is 2/3 completed, wheels to the left (right) 3/4 of a moving pivot and follows the right (left) three.

**TO CHANGE DIRECTIONS IN COLUMN OF TWOS (Par. 200)**

Being in March.

**Captain's Commands:** 1. **Column Left (Right), 2. March.**

**Captain:** Commands: 1. *Column Left (Right), 2. March.*

AT THE COMMAND MARCH

**Leading Rank:** Wheels to the left (right) on moving pivot (3 steps), taking the full step upon completion of the wheel.

**Captain:** Wheels to the left (right) and maintaining his position beside the Leading Rank.

**Rear Ranks:** Move straight to the front, wheeling on the same ground as the leading rank.

**TO CHANGE DIRECTIONS IN COLUMN OF THREES (Par. 200)**

Being in March.

**Captain's Commands:** 1. **Column Left (Right), 2. March.**

**Captain:** Commands: 1. *Column Left (Right), 2. March.*

AT THE COMMAND MARCH

**Leading Rank:** Wheels to the left (right) on moving pivot (4 steps), taking the full step upon completion of the wheel.

**Captain:** Wheels to the left (right) and maintaining his position beside the Leading Rank.

**Rear Rank:** Move straight to the front, wheeling on the same ground as the leading rank.

**TO CHANGE DIRECTIONS IN COLUMN OF SECTIONS (Par. 200)**

Being in March.

**Captain's Commands:** 1. **Column Left (Right), 2. March.**

**Captain:** Commands: 1. *Column Left (Right), 2. March.*

AT THE COMMAND MARCH

**Leading Rank:** Wheels to the left (right) on moving pivot (8 steps), taking the full step upon completion of the wheel.

**Captain:** Wheels to the left (right) and maintaining his position beside the Leading Rank.

**TO FORM LINE FROM COLUMN OF THREES (Par. 204)**

Being in March in Column of Threes and Halting.

**Captain's Commands:** 1. **Threes Left (Right)**, 2. **March**, 3. **Commandery**, 4. **Halt**.

**Captain:** Commands: 1. *Threes Left (Right)*.

Captain then marks time until the center of the column is one (1) pace from him and commands: 2. *March*. Captain moves to his left (right) takes his position 3 paces in front of the center of the commandery facing front. Captain adds 3. *Commandery*, 4. *Halt* as the wheel is completed.

AT THE COMMAND MARCH

**Knights:** Each three wheels to the left (right) on FIXED PIVOTS (3 steps).

Being in March in Column of Threes and continuing to march.

**Captain's Commands:** 1. **Threes Left (Right)**, 2. **March**, 3. **Guide Right**.

**Captain:** Commands: 1. *Threes Left (Right)*.

Captain then marks time until the center of the column is one (1) pace from him and commands: 2. *March*. Captain moves to his left (right) takes his position 3 paces in front of the center of the commandery and commands 3. *Guide Right* as the wheel is completed. Captain then marches to the front.

AT THE COMMAND MARCH

**Knights:** Each three wheels to the left (right) on FIXED PIVOTS (3 steps).

**ON RIGHT INTO LINE (Par. 205)**

Being in a Column of Threes and Right in front.

**Captain's Commands:** 1. **On Right into Line**, 2. **March**, 3. **Commandery**, 4. **Halt**, 5. **Front**.

**Captain:** Commands: 1. *On Right into Line*, 2. *March*.

AT THE COMMAND MARCH

**Leading Three:** Wheels to the right on a moving pivot (4 steps) and march straight to the front, aligning to the right.

**Captain:** Moves in front of the leading three to a position on the immediate right of the No. 1 Knight and with the leading three, marches four abreast to the front.

**Rear Three:** Marches a distance equal to its front (two paces) beyond the wheeling point of the threes next preceding (two paces to reach that point then two paces beyond for a total of 4 paces), and wheels to the right on a MOVING PIVOT and advances to the front.

**Captain:** After marching to the front a commandery distance Commands: 3. *Commandery*, 4. *Halt*.

AT THE COMMAND HALT

**Leading Three:** Halt. Leading three dresses to the right without command. Captain faces left and executes 4 backsteps into position to verify the alignment.

**Rear Three:** Advance into line, halting a few inches behind the line and step into line. Dressing to the right without command. (Par. 75)

**Captain:** Being satisfied with the alignment Commands: 5. *Front*, and takes his position three paces in front of the center of the commandery and faces front.

**ON LEFT INTO LINE (Par. 205)**

Being in a Column of Threes and Left in front.

**Captain's Commands:** 1. **On Left into Line**, 2. **March**, 3. **Commandery**, 4. **Halt**, 5. **Front**.

**Captain:** Commands: 1. *On Left into Line*, 2. *March*.

AT THE COMMAND MARCH

**Leading Three:** Wheels to the left on a moving pivot (4 steps) and march straight to the front, aligning to the left.

**Captain:** Moves in front of the leading three to a position on the immediate left of the No. 6 Knight and with the leading three, marches four abreast to the front.

**Rear Three:** Marches a distance equal to its front (two paces) beyond the wheeling point of the threes next preceding (two paces to reach that point then two paces beyond for a total of 4 paces), and wheels to the left on a MOVING PIVOT and advances to the front.

**Captain:** After marching to the front a commandery distance Commands: 3. *Commandery*, 4. *Halt*.

AT THE COMMAND HALT

**Leading Three:** Halt. Leading three dresses to the left without command. Captain faces right and

**Captain:** executes 4 backsteps into position to verify the alignment.

**Rear Three:** Advance into line, halting a few inches behind the line and step into line. Dressing to the left without command. (Par. 75)

**Captain:** Being satisfied with the alignment Commands: 5. *Front*, and takes his position three paces in front of the center of the commandery and faces front.

**TO FORM LINE TO THE FRONT FROM COLUMN OF THREES (Par. 207)**

**Captain's Commands:** 1. **Left (Right) Front into Line**, 2. **March**, 3. **Commandery**, 4. **Halt**, 5. **Front**.

**Captain:** Commands: 1. *Left (Right) Front into Line*, 2. *March*.

AT THE COMMAND MARCH

**Captain:** Moves in front of the leading three and takes position on the immediate right (left) of the No. 1 (6) Knight.

**Leading Three:** Continue straight to the front and with the Captain, march four abreast.

**Rear Three:** Oblique to the left (right) until they uncover the threes immediately in front of them, then moves to the front.

**Captain:** When the leading three have marched a commandery distance Commands:  
3. *Commandery*, 4. *Halt*.

AT THE COMMAND HALT

**Leading Three:** Halt. Leading three dresses to the right (left) without command.

**Rear Three:** Advance into line, halting a few inches behind the line and step into line. Dressing to the right (left) without command. (Par. 75)

**Captain:** Halts, faces left (right) and executes 4 backsteps into position to verify the alignment. Being satisfied with the alignment Commands: 5. *Front*, and takes his position three paces in front of the center of the commandery and faces front.

**TO CHANGE DIRECTION IN A COMMANDERY FRONT (Par. 209)**

Being halted in a Commandery front.

**Captain's Commands:** 1. **Section Left (Right) about**, 2. **March**, 3. **Forward**, 4. **March**, 5. **Guide Right (Left)**.

**Captain:** Commands: 1. *Section Left (Right) about*, 2. *March*.

**AT THE COMMAND MARCH**

**Captain:** Moves to his new position by the most direct route and takes position facing front, centered on the new commandery front.

**Knights:** Wheel to the Left (Right) on a fixed pivot.

**Captain:** Commands: 3. *Forward* as the movement nears completion in time to command 4. *March* the instant the movement completes and then adds 5. *Guide Right (Left)*.



**FRONT OPEN FILES (Par. 220)**

- Captain's Commands:** 1. **Front Open Files**, 2. **March**, 3. **Guide Right**, 4. **Commandery**, 5. **Halt**.
- Captain:** Commands: 1. *Front Open Files*, faces to the front and Commands: 2. *March*, 3. *Guide Right*.
- AT THE COMMAND MARCH
- Captain:** March straight to the front, carefully preserving the intervals.
- No. 1 Knight of each 3:**
- No. 2 Knight of each 3:** Take up the march on the third step. (DO NOT MARK TIME)
- No. 3 Knight of each 3:** Take up the march on the fifth step. (DO NOT MARK TIME)
- Captain:** Commands: 4. *Commandery*, 5. *Halt*.
- All: Halt

**FRONT INTO LINE (Par. 221)**

- Captain's Commands:** 1. **Front into Line**, 2. **March**, 3. **Right Dress**, 4. **Front**.
- Captain:** Commands: 1. *Front into Line*, 2. *March* from his position three paces in front of the center and facing the commandery.
- AT THE COMMAND MARCH
- Front Line:** Stand Fast.
- Second Line:** Advance two (2) paces to the front and halt.
- Third Line:** Advance four (4) paces to the front and halt.
- Captain:** The Knights having arrived in line Commands: 3. *Right Dress*. Moves by the shortest route to a point two paces to the right of the No. 1 Knight and in prolongation of the alignment, verifies the alignment and being satisfied, Commands: 4. *Front*. Takes his position three paces in front of the center of the commandery and faces front.

**OPEN ORDER (Par. 227)**

Being in march in a Column of Twos.

**Captain's Commands:** 1. **Open Order**, 2. **March**.

**Captain:** Commands: 1. *Open Order*, 2. *March*, from his position on the immediate left of the No. 2 Knight. March is given on the left foot.

**AT THE COMMAND MARCH**

**Knights in Column:** The left knights of the twos advance one step and execute Left Oblique one (1) step and turn back to the front and continue the march. The right knights of the twos advance two (2) steps to the front and then execute Right Oblique one (1) step and turn back to the front and continue the march.

**Captain:** Advance one step and execute Left Oblique one (1) step and turn back to the front and continue the march.

(NOTE: If followed by Commandery Halt for the purpose of the sword manual the Captain will advance two (2) paces beyond the Sir Knights and flank right and place himself centered on the lines and facing down the lines as shown below before giving other commands.)

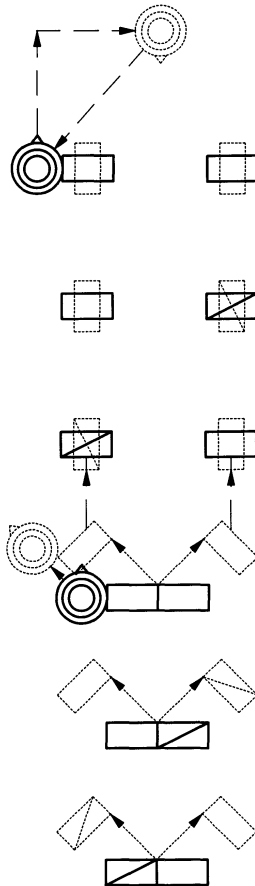

**CLOSE ORDER (Par. 228)**

When open order was executed from a Column of Twos.

**Captain's Commands:** 1. **Close Order**, 2. **March**, 3. **Guide Left (Right)**.

**Captain:** Commands: 1. *Close Order*, 2. *March*, from his position on the immediate left of the No. 2 Knight. March is given on the right foot.

AT THE COMMAND MARCH

**Knights in Column:** The left knights of the twos advance one step and execute Right Oblique one (1) step and turn back to the front and continue the march. The right knights of the twos advance two (2) steps to the front and then execute Left Oblique one (1) step and turn back to the front and continue the march.

**Captain:** Advance one step and execute Right Oblique one (1) step and turns back to the front and continue the march. Commands: 3. *Guide Left (Right)*, as the twos unite.

**THREES IN CIRCLE LEFT WHEEL (PAR. 233)**

Being Right in Front.

**Captain's Commands:** 1. **Threes in Circle, Left Wheel, 2. March, 3. Guide Left.**

**Captain:** Commands: 1. *Threes in Circle, Left Wheel, 2. March.*

AT THE COMMAND MARCH

**Knights in Column of 3:** Wheel in full circle to the left on fixed pivots (12 steps).

**Captain:** Advances two (2) paces and marks time during the wheeling of the threes. He gives the command: 3. *Guide Left* as the threes complete the wheel, at which the commandery again marches to the front in Column of Threes. He steps off with the leading three as they arrive on his right

The command Guide Left serves the same purpose as Forward March.

**THREES IN CIRCLE RIGHT WHEEL (PAR. 233)**

Being Left in Front.

**Captain's Commands:** 1. **Threes in Circle, Right Wheel, 2. March, 3. Guide Right.**

**Captain:** Commands: 1. *Threes in Circle, Right Wheel, 2. March.*

AT THE COMMAND MARCH

**Knights in Column of 3:** Wheel in full circle to the right on fixed pivots (12 steps).

**Captain:** Advances two (2) paces and marks time during the wheeling of the threes. He gives the command: 3. *Guide Right* as the threes complete the wheel, at which the commandery again marches to the front in Column of Threes. He steps off with the leading three as they arrive on his left

The command Guide Right serves the same purpose as Forward March.

**TO FORM COLUMN OF SECTIONS FROM A COLUMN OF THREES (Par. 234)**

Being in March.

**Captain's Commands:** 1. **Form Section Left (Right) Oblique, 2. March, 3. Forward, 4. March.**

**Captain:** Commands: 1. *Form Section Left (Right) Oblique, 2. March.*

AT THE COMMAND MARCH

**Leading Three:** Take up the Half Step.

**Rear Three:** Oblique to the left (right) until they uncover the threes immediately in front of them and then resume the forward march.

**Captain:** Moves to his left (right) and takes his position on the left (right) of the No. 6 (1) Knight and Commands: 3. *Forward, 4. March.* March is given the instant the threes unite in sections.

AT THE COMMAND MARCH

**Each Knight:** Marches to the front at a full step.

**TO FORM COMMANDERY FROM A COLUMN OF THREES (Par. 234)**

Being in March.

**Captain's Commands:** 1. **Form Commandery Left (Right) Oblique**, 2. **March**, 3. **Forward**, 4. **March**, 5. **Guide Right (Left)**.

**Captain:** Commands: 1. *Form Commandery Left (Right) Oblique*, 2. *March*.

AT THE COMMAND MARCH

**Leading Three:** Take up the Half Step.

**Rear Three:** Oblique to the left (right) until they uncover the first three and then resume the forward march. Upon arriving at the new line of march take up the half step without command.

**Captain:** Moves to his position 3 paces in front the center of the Commandery front and after the front is formed Commands: 3. *Forward*, 4. *March*, 5. *Guide Right (Left)*.

AT THE COMMAND MARCH

**Each Knight:** Marches to the front at a full step.

**TO FORM LINE TO THE FRONT FACED TO THE REAR (Par. 241)**

Being in March and being in a column of threes.

**Captain's Commands:** **1. Right Front into Line, Faced to the Rear, 2. March, 3. Commandery, 4. Halt, 5. Front.**

**Captain:** Commands: *1. Right Front into Line, Faced to the Rear, 2. March.*

AT THE COMMAND MARCH

**Captain:** Takes position on the immediate left of the No. 3 Knight.

**Leading Three:** Continue straight to the front and with the Captain, march four abreast.

**Rear Three:** Oblique to the Right until they uncover the threes immediately in front of them, then moves to the front.

**Captain:** When the leading three have marched a commandery distance, Commands: *3. Commandery, 4. Halt.*

AT THE COMMAND HALT

**Leading Three:** Wheels left about on a fixed pivot, halts and dresses to the right without command. (Par. 75)

**Rear Three:** Marches forward to the established line, wheels to the left about, halts and dresses to the right without command. (Par. 75)

**Captain:** Moves by the left flank to a point two paces on the right of the No. 1 Knight, faces about facing down the prolongation of the new alignment. After the wheeling by the threes has been completed, and being satisfied with the alignment, Commands: *5. Front.* Takes his position three paces in front of the center of the commandery and faces front.

**RIGHT OBLIQUE (Par. 257)**

Being Halted.

**Captain's Commands:** 1. **Right (Left) Oblique**, 2. **March**.

**Captain:** Facing front commands: 1. *Right (Left) Oblique*.

**Knights:** The command Right (Left) O is the preparatory command; each Knight executes half right (left) face on "blique".

**Captain:** Commands: 2. *March*.

**Knights:** March in the new direction. (Read Par. 79).

**FORWARD MARCH (Par. 257)**

To resume the original direction of march.

**Captain's Commands:** 1. **Forward**, 2. **March**.

**Captain:** Commands: 1. *Forward* 2. *March*.

Captain gives the command *March* as the left (right) foot strikes the ground.

AT THE COMMAND MARCH

**Guides and Knights:** Each Knight executes half left (right) flank and marches in the original direction.



## WHEEL SUBDIVISIONS IN CIRCLE CONSECUTIVELY (Par. 286)

THREES IN CIRCLE RIGHT (LEFT) WHEEL  
SECTION IN CIRCLE LEFT (RIGHT) WHEEL

**Captain's Commands:** 1. *Threes in Circle Right (Left) Wheel*, 2. *March*, 3. *Section in Circle Left (Right) Wheel*, 4. *March*, 5. *Commandery*, 6. *Halt*, 7. *Left (Right)*, 8. *Dress*, 9. *Front*.

**Captain:** Facing the Commandery, commands: 1. *Threes in Circle Right (Left) Wheel*, 2. *March*.

AT THE COMMAND MARCH

**Knights in Line:** Each three wheels in circle to the right (left) on fixed pivots (3 steps to the quarter).

**Captain:** Stands fast and commands: 3. *Section in Circle Left (Right) Wheel* in time to add 4. *March* as the threes reunite in line.

AT THE COMMAND MARCH

**Knights in Line:** Each section wheels in circle to the left (right) on fixed pivots (6 steps to the quarter).

**Captain:** Backsteps a sufficient distance to permit the marching flank of the section to clear him, halts and after the section has cleared him, marches forward to his original position halts and when the section has completed about one-half of the circle, moves to his right (left) to a point two paces on the right (left) of the No. 6 (No. 1) Knight and in line with the that Knight. As the marching flank is about three paces from the line Commands: 5. *Commandery* 6. *Halt*. Halt being given so the marching flank halts three paces or less from the line.

AT THE COMMAND HALT

**Knights:** Halt.

**Captain:** Commands: 7. *Left (Right)*, 8. *Dress*.

AT THE COMMAND DRESS

**Knights:** The Knights successively starting with the No. 5 (No. 2) Knight move up in quick time, shortening the last step so as to be about six inches behind the alignment; which must never be passed; each Knight then executes *Eyes Left (Right)*, and successively moves to the line taking steps of two or three inches, places his left (right) arm lightly against the right (left) arm of the Knight on his left (right) so that his eyes and shoulders are on a line with those of the Knights on his left (right), shoulders square to the front.

**Captain:** Being satisfied with the alignment, Commands: 9. *Front*, and moves to his position three paces in front of the center of the commandery and faces front.

**TO WHEEL ON THE CENTER (Par. 292)**

Being in Line Halted.

**Captain's Commands:** 1. **On Center in Circle Left (Right) Wheel**, 2. **March**, 3. **Commandery**, 4. **Halt**, 5. **On Center**, 6. **Dress**, 7. **Front**.

**Captain:** Commands: 1. *On Center in Circle Left (Right) Wheel*.

**Second (First) 3 Leader:** Commands: 1. *Second (First) Three, About*, 2. *Face*..

**Second (First) Three:** Executes about face.

**Captain:** Commands: 2. *March*.

**AT THE COMMAND MARCH**

**No. 1 and No. 6 Knight:** March in circle to the left (right) (3 steps to the quarter) conducting the marching flank of their respective threes.

**Knights:** Wheel in circle to the left (right) on a fixed pivot (a point between the No. 3 Knight of the first three and the No. 1 Knight of the second three).

**Captain:** Stand fast, then Commands: 3. *Commandery* 4. *Halt*. as the circle is completed.

**AT THE COMMAND HALT**

**Knights:** Halt.

**Second (First) 3 Leader:** Commands: 3. *Second (First) Three, About*, 4. *Face*.

**Second (First) Three:** Executes about face.

**Captain:** Commands: 5. *On Center*, 6. *Dress*.

**AT THE COMMAND DRESS**

**Knights:** Dress on the No. 3 Knight of the first three who faces front.

**Captain:** Moves, by the shortest route, to a position two paces to the right of the No. 1 Knight and a prolongation of the alignment, verifies the alignment. Being satisfied with the alignment he Commands: 7. *Front*, and takes his position three paces in front of the center of the Commandery and faces front.

**THREES IN CIRCLE RIGHT AND LEFT WHEEL (Par. 297)**

Being in a column of sections with the right in front.

**Captain's Commands:** 1. **Threes in Circle Right and Left Wheel**, 2. **March**, 3. **Guide Left**.

**Captain:** Commands: 1. *Threes in Circle Right and Left Wheel*, 2. *March*.

AT THE COMMAND MARCH

**Captain:** Advances two (2) paces and marks time during the wheeling of the threes.

**Knights in Column:** Right threes wheel in circle to the right, and left threes wheel in circle to the left on fixed pivots (3 steps to the quarter).

**Captain:** Gives command: 5. *Guide Left* as the threes unite into sections and steps off with the section when they arrive on his right.

Guide Left serves the same purpose as Forward March

**THREES IN CIRCLE LEFT AND RIGHT WHEEL (Par. 297)**

Being in a column of section with the left in front.

**Captain's Commands:** 1. **Threes in Circle Left and Right Wheel**, 2. **March**, 3. **Guide Right**.

**Captain:** Commands: 1. *Threes in Circle Left and Right Wheel*, 2. *March*.

AT THE COMMAND MARCH

**Captain:** Advances two (2) paces and marks time during the wheeling of the threes.

**Knights in Column:** Left threes wheel in circle to the left, and right threes wheel in circle to the right on fixed pivots (3 steps to the quarter).

**Captain:** Gives command: 5. *Guide Right* as the threes unite into sections and steps off with the section when they arrive on his left.

Guide Right serves the same purpose as Forward, March.

**TO WHEEL THREES IN CIRCLE ALTERNATELY (Par. 298)**

Being in march with the right in front.

**Captain's Commands:** 1. **Right Threes in Circle Right Wheel**, 2. **March**, 3. **Left Threes in Circle, Left Wheel**, 4. **March**, 5. **Guide Left**.

**RIGHT THREES IN CIRCLE RIGHT WHEEL (Par. 298)**

**Captain:** Commands: 1. *Right Threes in Circle Right Wheel*, 2. *March*.

AT THE COMMAND MARCH

**Right Three:** Wheel in circle to the right on fixed pivots (3 steps to the quarter).

**Captain:**  
**Left Three:** Continue marching to the front.

**LEFT THREES IN CIRCLE LEFT WHEEL (Par. 298)**

**Captain:** The circle being nearly completed, commands: 3. *Left Threes in Circle Left Wheel*, and adds: 4. *March*, the instant the circle of the Right Three is completed. Captain advances two (2) paces and Marks Time during the wheeling of the Left Threes.

**Right Three:** March to the front.

**Left Three:** Wheel to the left on fixed pivots (3 steps to the quarter).

**Captain:** Commands: 5. *Guide Left* as the threes unite into sections and steps off with the section when it arrives on his right.

Guide Left serves the same purpose as Forward, March.

**THREES BREAK FROM THE RIGHT TO MARCH TO THE LEFT (Par. 300)**

**Captain's Commands:** 1. **Threes**, 2. **Break from the Right to March to the Left**, 3. **March**.

**Captain:** Commands: 1. *Threes*, 2. *Break from the Right to March to the Left*, 3. *March*.

AT THE COMMAND MARCH

**First Three (Right):** Moves a distance of three paces straight to the front (in 4 steps), then wheel to the left on a moving pivot (4 steps) marching parallel to the front of the commandery.

**Second Three:** STAND FAST, DO NOT MARK TIME.  
The second three moves to the front a distance of three paces (in 4 steps), after standing fast, when the first three arrive opposite its right file, wheels to the left on a moving pivot (4 steps) and follows the first three.

**Captain:** Stands fast, faces right as the First Three approach and takes his position on the immediate left of the No. 3 Knight.

**FROM RIGHT TO REAR INTO LINE (Par. 303)**

Being at a halt, in a Commandery front.

**Captain's Commands:** 1. **From Right to the Rear into Line**, 2. **March**, 3. **Front**.

**Captain:** Commands: 1. *From Right to Rear into Line*, (from his position three paces in front and facing the Commandery), Having given the preparatory command, moves to a position three paces in front of and facing the No. 1 Knight and Commands: 2. *March*.

AT THE COMMAND MARCH

**Knights in Line:** Execute threes right about on fixed pivots (6 steps).

**Captain:** Moves to position on the immediate left of the No. 3 Knight.

HAVING COMPLETED THE THREES RIGHT ABOUT

**Leading Three:** Marches four abreast with the Captain to the rear a threes distance (2 paces), when they execute (on the 3rd count) threes left on a moving pivot (4 steps) and Halt, dressing to the right on the No. 1 Knight without command (Par. 75).

**Captain:** Marches four paces beyond the wheeling point of the leading three (two paces beyond the No. 1 Knight). Halts, faces about in position to verify the alignment.

**Last Three:** The last three, after completing Threes Right About, Mark Time and step off in echelon on the 3rd count and execute Threes Left (the second three in place) on moving pivot (4 steps), and then advance into line, halting a few inches behind the line, dressing to the right without command. (Par. 75)

**Captain:** The last three having arrived in line, verifies the alignment, being satisfied, commands: 3. *Front*. Takes his position three paces in front of the center of the Commandery and faces the front.

**THREES RIGHT ABOUT BY THREES ON LEFT INTO LINE FACED TO THE REAR (Par. 304)**

**Captain's Commands:** 1. **Threes Right About**, 2. **By Threes On left into Line Faced to the Rear**, 3. **March**, 4. **Front**.

**Captain:** Commands: 1. *Threes Right About*, 2. *By Threes On Left into Line Faced to the Rear*. Moves to a point three paces in front of and facing the No. 1 Knight and Commands: 3. *March*.

## AT THE COMMAND MARCH

**Knights:** Each three executes Threes Right About (6 steps), advance two paces to the rear, and executes By Threes On Left into Line Faced to the Rear. The first (right three), after moving two paces to the rear, executes threes left on a moving pivot (4 steps), advances two paces in the new direction, wheels to the left about on a fixed pivot (6 steps), halts and dresses to the right (on the No. 1 Knight) without command (Par. 75). The remaining three march to the rear until opposite their places in line plus 54 inches, then change direction to the left, wheeling on a moving pivot (4 steps), pass beyond the line, wheel to the left about on a fixed pivot (6 steps), halt and dress to the right without command (Par. 75).

**Captain:** Faces left and advances two (2) paces marks time two (2) counts and then advances to a position in prolongation of the new alignment and faces right and advances to two paces to the right of the No. 1 Knight. After the wheeling by threes has been completed, and being satisfied with the alignment, commands: 4. *Front*. Takes his position three paces in front of the center of the Commandery and faces front.

**TO INVERT THE COLUMN OF THREES (Par. 306)**

Being right (left) in front.

**Captain's Commands:** 1. **Left (Right) in Front**, 2. **In Circle Left (Right) Wheel**, 3. **March** 4. **Guide Right (Left)**.

**Captain:** Commands: 1. *Left(Right) in Front*, 2. *In Circle Left (Right) Wheel*, 3. *March*.

AT THE COMMAND MARCH

**Rear Three:** Marks Time until the leading three completes three quarters of the circle (12 steps).

**Leading Three:** Wheel to the left (right) on a moving pivot (4 steps) and wheel in behind the second three.

**Rear Three:** Resume the march on the 13th count.

**Captain:** Moves right (left) about, facing the rear and observes the movement. As the rear three resumes the march Commands: 4. *Guide Right (Left)*. Takes his position on the right (left) of the No. 4 (3) Knight when the Knight is opposite him.



**FORM PASSION CROSS (Par. 314)**

Being in march in a Column of Threes to form cross.

**Captain's Commands:** 1. **Form Passion Cross**, 2. **March**, 3. **Forward**, 4. **March**, 5. **Guide Center**.

**Captain:** Commands: 1. *Form Passion Cross*, 2. *March*, from his position on the immediate left of the No. 3 Knight.

AT THE COMMAND MARCH

**Knights in Column:** The first three take up the half step to form the cross arm of the cross. The second three execute Right by File (Par. 215) in trace of the No. 2 Knight of the first three to form the lower arm of the cross and take up the half step. Knights in file march at facing distance (Par. 187).

**Captain:** Places himself in position to observe the forming of the cross, and as the cross nears completion takes his place at facing distance (10 inches) in front of the No. 2 Knight and commands: 3. *Forward*, 4. *March*, 5. *Guide Center*, taking his position at command No. 4.

MARCH THE CROSS A COMMANDERY DISTANCE BEFORE REFORMING THREES.

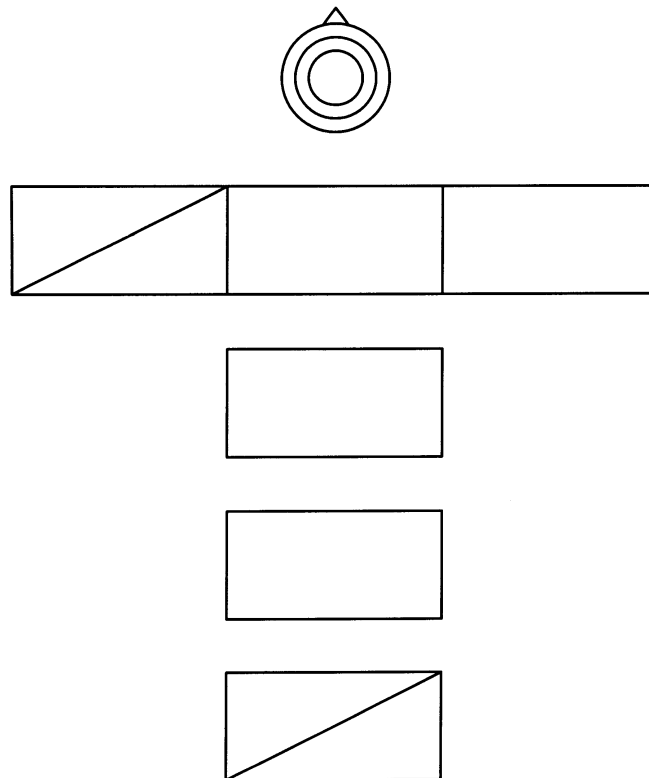

**FORM PASSION CROSS (Par. 314)**

Being in march in a Column of Twos to form cross.

**Captain's Commands:** 1. **Form Passion Cross**, 2. **March**, 3. **Forward**, 4. **March**, 5. **Guide Center**.

**Captain:** Commands: 1. *Form Passion Cross*, 2. *March*, from his position on the immediate left of the No. 2 Knight.

AT THE COMMAND MARCH

**Knights in Column:** The first two execute Right by Files (Par. 215) and advance in half step to form the upper arm of the cross. The second two guide to the left (No. 4) and right (No. 3) to form the arms, until they uncover the No. 2 knight of the first two and then move to the front until they arrive at a position directly to the right and left and adjacent to the No. 2 Knight of the first two and then take up the half step. The third two execute Right by File in trace of the No. 2 Knight of the first two to form the lower arm of the cross and take up the half step. Knights in file march at facing distance (Par. 187).

**Captain:** Places himself in position to observe the forming of the cross, and as it nears completion, takes his position three paces in front of the No. 1 Knight and commands: 3. *Forward*, 4. *March*, 5. *Guide Center*, taking his position at command No. 4.

MARCH THE CROSS A COMMANDERY DISTANCE BEFORE REFORMING TWOS.

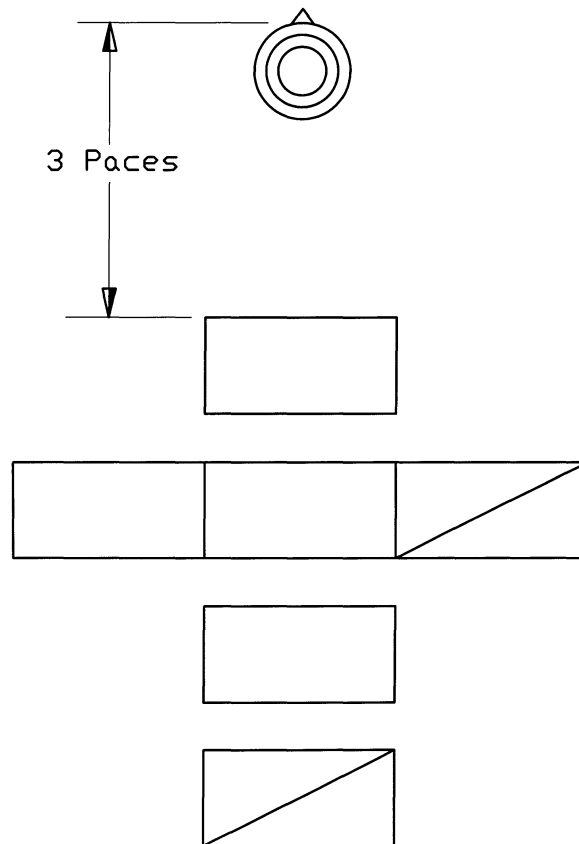

**FORM THREES (Par. 315)**

When cross was formed from a Column of Threes.

**Captain's Commands:** 1. **Form Threes**, 2. **March**, 3. **Forward**, 4. **March**, 5. **Guide Left**.

**Captain:** Commands: 1. *Form Threes*, 2. *March*.

AT THE COMMAND MARCH

**Knights in Column:** The first threes execute half step. The second threes execute Left Front into Line (Par. 216) in trace of the leading threes and take up the half step without command.

**Captain:** As the Knights unite into column of threes, takes position on the left of the No. 3 Knight and commands: 3. *Forward*, 4. *March*, 5. *Guide Left*.

**FORM TWOS (Par. 315)**

When cross was formed from a Column of Twos.

**Captain's Commands:** 1. **Form Twos**, 2. **March**, 3. **Forward**, 4. **March**, 5. **Guide Left**.

**Captain:** Commands: 1. *Form Twos*, 2. *March*.

AT THE COMMAND MARCH

**Knights in Column:** The first and third twos execute Left Front into Line (Par. 216). The third two then execute mark time until marching distance develops with the second two. The second two mark time for two counts and then guide right (No. 4) and left (No. 3) until they can move to the front in trace of the leading two as marching distance develops.

**Captain:** As the Knights unite into column of twos, takes position on the left of the No. 2 Knight and commands: 3. *Forward*, 4. *March*, 5. *Guide Left*.

**FORM CROSS OF ST. ANDREW (Par. 321)**

Being in a column of threes and right in front.

**Captain's Commands:** 1. **Form Cross of St. Andrew**, 2. **March**, 3. **Forward**, 4. **March**, 5. **Guide Center**.

**Captain:** Commands: 1. *Form Cross of St. Andrew*, from his position directly to the left of the No. 3 knight.

**First 3 Leader:** Commands: 1. *Files from Right and Left*, 2. *Front into Echelon*.

**Second 3 Leader:** Commands: 1. *Files from the Center*, 2. *Front into Echelon*.

**Captain:** Commands: 2. *March*.

**AT THE COMMAND MARCH**

**First Three:** The No. 1 and No. 3 Knight of the first three march straight to the front at half step and preserving with the greatest care the interval between them. The No. 2 Knight mark time one count, and resume the march at facing distance\* in echelon.

**Second Three:** The center knight of the second three (No. 5 Knight) advances to the front with shortened steps and close to a facing distance\* behind the center Knight of the first three then takes up the half step. The other files mark time one count and resume the march at facing distance\* in echelon, the Knights marching at the half step and carefully covering their counterparts in the first three.

**Captain:** Takes position three paces in front and in the center of the cross, and commands: 3. *Forward*, 4. *March*, 5. *Guide Center*.

**MARCH THE CROSS A COMMANDERY DISTANCE BEFORE REFORMING THREES.**

\*Facing distance is ten inches.

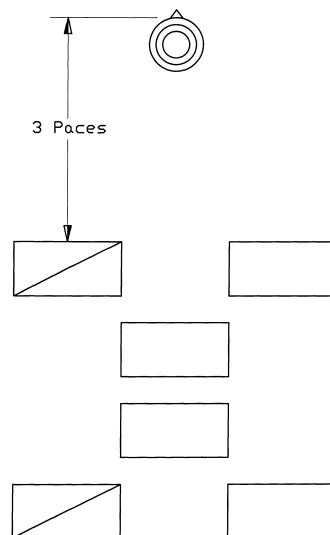

**FORM THREES (Par. 322)**

**Captain's Commands:** 1. **Form Threes**, 2. **March**, 3. **Forward March**, 4. **Guide Left**.

**Captain:** Commands: 1. *Form threes*.

**First 3 Leader:** Commands: 1. *Front into Line*.

**Second 3 Leader:** Commands: 1. *Front into Line*.

**Captain:** Captain commands: 2. *March*.

**AT THE COMMAND MARCH**

**First Three:** The No. 1 and No. 3 Knight of the first three mark time 2 counts and take up the half step, the No. 2 Knight of the first three moves forward at half step.

**Second Three:** The center knight (No. 5 Knight) marks time. The other knights move into line and mark time upon arriving in line and all resume half step when 2 paces behind the first three.

**Captain:** Captain moves to his position beside the No. 3 Knight and commands: 3. *Forward*, 4. *March*, 5. *Guide Left*.

**FORM EGYPTIAN CROSS (Par. 323)**

Being in a column of threes and right in front.

**Captain's Command:** 1. **Form Egyptian Cross**, 2. **March**, 3. **Forward**, 4. **March**, 5. **Guide Center**.

**Captain:** Commands: 1. *Form Egyptian Cross*.

**First 3 Leader:** Commands: 1. *Half step*.

**Second 3 Leader:** Commands: 1. *Right by Files*.

**Captain:** Commands: 2. *March*.

**AT THE COMMAND MARCH**

**First Three:** Oblique to the right one step and then takes up the half-step.

**Second Three:** Executes right by file and moves to the front to follow in trace of the No. 2 Knight of the first three taking up the half step when they arrive at facing distance. (10 inches)

**Captain:** Places himself in position to observe the forming of the cross and, as it is completed, takes his position three paces in front of the No. 2 Knight and commands: 3. *Forward*, 4. *March*, 5. *Guide Center*, being in position at 4.

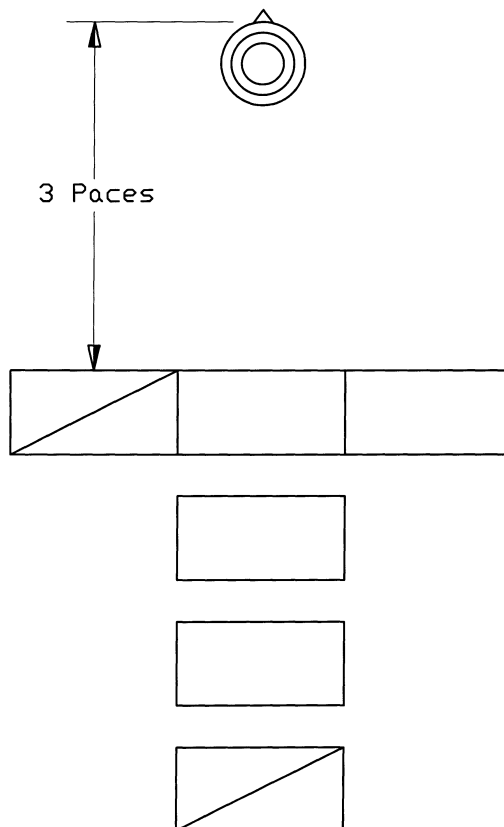

**FORM COLUMN (Par. 324)**

To Form a column of threes.

**Captain's Commands:** 1. **Form Threes**, 2. **March**, 3. **Guide Left**.

**Captain:** Commands: 1. *Form Threes*.

**First 3 Leader:** Commands: 1. *Forward*.

**Second 3 Leader:** Commands: 1. *Left Front into Line*.

**Captain:** Commands: 2. *March*.

AT THE COMMAND MARCH

**First Three:** Oblique to the left one step and then march forward in full step.

**Second Three:** Executes Left Front into Line in trace of the leading three at marching distance. (2 paces)

**Captain:** Takes his position on the immediate left of the No. 3 Knight, and commands: 3. *Guide Left*.

**FORM TRIANGLE (Par. 328)**

**Captain's Commands:** 1. **Form Triangle**, 2. **March**, 3. **Forward**, 4. **March**, 5. **Guide Center**.

**Captain:** Commands: 1. *Form Triangle*, 2. *March*.

AT THE COMMAND MARCH

**No. 2 Knight:** Takes one (1) full step forward and takes up the half step.

**No. 1 & 3 Knights:** The No. 1 and No. 3 Knights of the leading three mark time one (1) count then move forward, while shortening the interval from the No. 2 Knight and closing the distance between them until they are shoulder to shoulder and take up the half step at facing distance (10 inches) behind the No. 2 Knight.

**Second Three:** March straight to the front closing the distance from the No.1 and No. 3 Knights to form the base of the Triangle and then take up the half step at facing distance (10 inches) behind the No. 1 & No. 3 Knights of the first three.

**Captain:** Takes position three paces in front and in the center of the triangle, and commands: 3. *Forward*, 4. *March*, 5. *Guide Center* being in position at 4.

MARCH TRIANGLE A COMMANDERY DISTANCE

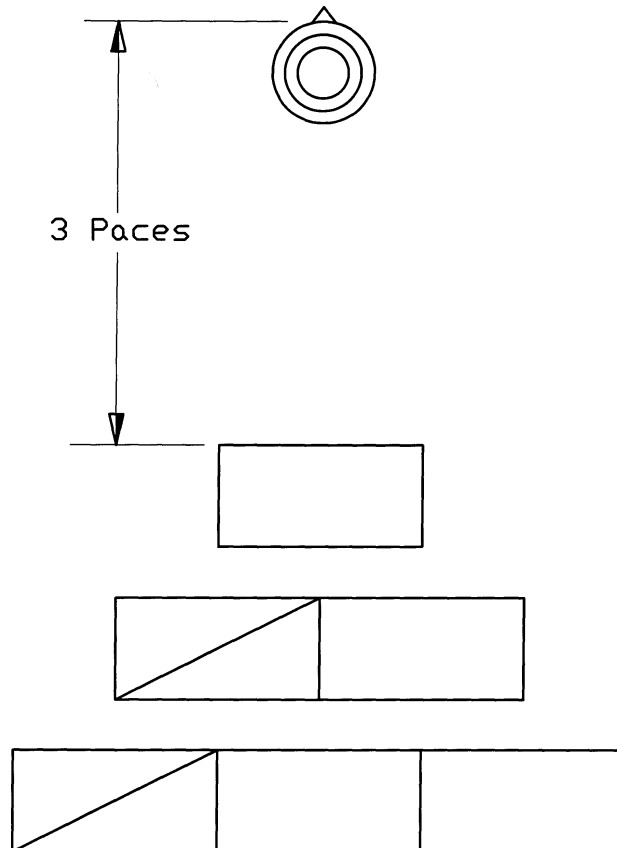



**FORM THREES (Par. 329)**

**Captain's Commands:** 1. **Form Threes**, 2. **March**, 3. **Forward**, 4. **March**, 5. **Guide Left**.

**Captain:** Commands: 1. *Form Threes*, 2. *March*.

**No. 2 Knight:** Takes up the half step.

**No. 1 & 3 Knights:** The No. 1 and No. 3 Knights of the leading three move to the right and left to place themselves on the immediate right and left of the No. 2 Knight and take up the half step.

**Second Three:** Mark time and takes up the half step as soon as marching distance (2 paces) is gained.

**Captain:** Moves to his position on the immediate left of the No. 3 Knight and commands:  
3. *Forward*, 4. *March*, 5. *Guide Left*.

**SPECIAL MOVEMENT (Combine parts of Par. 209 & 233)**

Being in Section.

**Captain's Commands:** 1. **Display Threes in Circle Right and Left Wheels**, 2. **March**, 3. **Guide Left**.

**Captain:** Commands: 1. *Display Threes in Circle Right and Left Wheels* 2. *March*.

AT THE COMMAND MARCH

**Right Threes:** Execute Threes Right About (fixed pivot 6 steps), followed by Threes in Circle Left Wheel (fixed pivot 12 steps), followed by another Threes Right About (fixed pivot 6 steps).

**Left Threes:** Execute Threes Left About (fixed pivot 6 steps), followed by Threes in Circle Right Wheel (fixed pivot 12 steps), followed by another Threes Left About (fixed pivot 6 steps).

**Captain:** Advances two (2) paces and marks time during the wheeling of the threes. He gives the command: 3. *Guide Left* as the threes complete the last wheel, the section again marches to the front. He steps off with the section as they arrive on his right